

VOLVO PENTA

Volvo Penta of the Americas
1300 Volvo Penta Drive
Chesapeake, Virginia 23320-9810

Service Bulletin

| Group | Number | Version |
|-------|--------|---------|
| 25-1 | 16 | 01 |

Exhaust Riser Gasket

Gas Engines

Distribution: M

Date: 04-2010

Binder: C

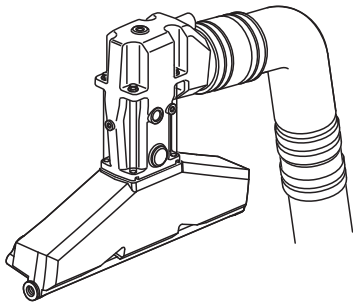

Applies to all gas engines with iron exhaust manifolds, 1993 to present.

Does **not** apply to catalyst gas engines.

Does **not** apply to pre-joint venture gas engines.



The procedure for installing the riser gaskets has been updated to improve sealing. The new procedure was implemented in production in April 2010. The new procedure should also be used whenever installing riser gaskets during normal service or repair work.

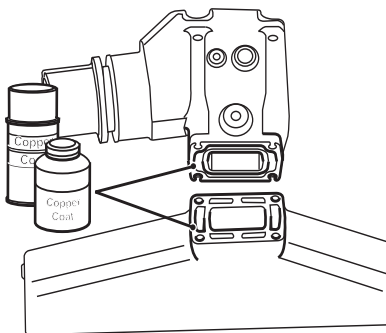

Change to Procedure:

Before installing a riser gasket, coat the mating surfaces of both the manifold and the riser with a copper-based, heat-resistant gasket compound.

Examples:

Permatex Copper Spray-a-Gasket® (80697)

K&W Copper Coat® (401612)

Aerosol or brush-on applications are both acceptable.

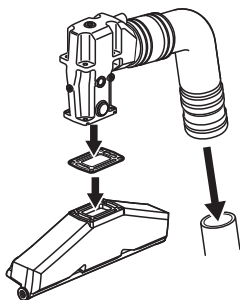

Install the riser gasket and then finish the repair according to the instructions or workshop manual.

V6 and V8

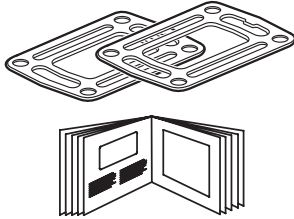

Riser gaskets for V6 and V8 engines are sold in a kit, **3863191** (see P-25-1-1) which contains two gaskets and instructions. The instructions have been revised to include the updated procedure.

IMPORTANT! The instructions contain detailed steps for surface preparation, gasket installation and torque that are necessary for proper sealing of the gaskets. If these steps are not followed, leakage at the gasket may occur.

3.0L

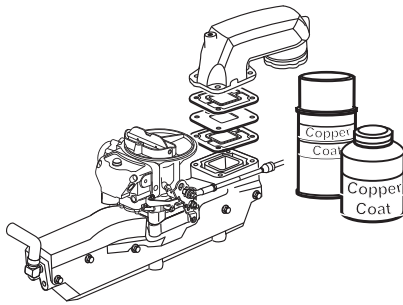

Use the procedure listed in the workshop manual, adding the step about coating the bare metal gasket surfaces with gasket compound.