

VOLVO PENTA

Volvo Penta of the Americas
1300 Volvo Penta Drive
Chesapeake, Virginia 23320-9810

Service Bulletin

Group	Number	Version
20-0	11	03

3.0 Liter Engine Upgrades

LK, BY, WT, and EF Models

Distribution: M

Date: 09-2006

Binder: C

This bulletin replaces two older versions of the bulletins with the same numbers. The information from the two older bulletins have been consolidated and provided in this document to ensure that all pertinent information is available for carrying out an upgrade on 3.0 Liter engines.

The specific upgrade kits are described below. For LK and BY models, please see below. For EF models, please see *EF Model Upgrade* on page 4. For WT models, please see *WT Model Upgrade* on page 4.

LK and BY Model Upgrades

In its continued effort to improve product reliability and performance and increase customer satisfaction, Volvo Penta of the Americas, Inc., has introduced a number of upgrades to the 3.0 liter LK and BY engines. In addition, Volvo Penta has decided to upgrade a number of units already in use. Volvo Penta will mail letters with information regarding the upgrades to registered owners.

If you have any boats with 3.0 liter engines in your inventory, please check serial and specification numbers. If any engines fall within the serial number range listed below, you should perform the applicable upgrade before you sell the boat.

NOTE! Please read the following information thoroughly. It contains instructions for completing four different upgrades, requiring:

- Three unique kits
- Five different procedures:
 1. A modification to the cooling system to optimize cooling water distribution.
 2. A new power steering pump belt to extend the belt's service life.
 3. A different base timing specification to make the engine less sensitive to low octane fuel.
 4. A modification to the alternator wiring to reduce the engine's electrical systems sensitivity to any voltage drop in the boat's electrical wiring.
 5. An improvement in the protection of the starter motor. For additional information, please see *Starter Motor* on page 3.

For specific information that is provided in the installation instructions included in kit PNs 3858253, 3858269, and 3858271, please refer to the document entitled *Field Upgrade Kits 3.0 Liter Engines* (PN 3858254).

Upgrade No. 1 – Order Kit P/N 3858253

Model	Specification No.	Serial No.
LK (power steering)	3868647	All
BY (power steering)	3868748	Lower than 4110160643

Upgrade No. 1 consists of the following:

1. A modification to the cooling system to optimize cooling water distribution.
2. A new power steering pump belt to extend the belt's service life.
3. A different base timing specification to make the engine less sensitive to low octane fuel.
NOTE! The minimum octane requirement specified in the owner's manual remains the same.
4. A modification to the alternator wiring to reduce the engine's electrical systems sensitivity to any voltage drop in the boat's electrical wiring.
5. An improvement in the protection of the starter motor.
NOTE! For additional information, please see *Starter Motor* on page 3.

Upgrade No. 2 – Order Kit P/N 3858269

Model	Specification No.	Serial No.
LK (mechanical steering)	3868646	All
BY (mechanical steering)	3868747	Lower than 4110162226

Upgrade No. 2 consists of the following:

1. A modification to the cooling system to optimize cooling water distribution.
2. A different base timing specification to make the engine less sensitive to low octane fuel.
NOTE! The minimum octane requirement specified in the owner's manual remains the same.
3. A modification to the alternator wiring to reduce the engine's electrical systems sensitivity to any voltage drop in the boat's electrical wiring.
4. An improvement in the protection of the starter motor.
NOTE! For additional information, please see *Starter Motor* on page 3.

Upgrade No. 3 – Order Kit P/N 3858271

Model	Specification No.	Serial No.
BY (power steering)	3868748	Lower than 4110166329

Upgrade No. 3 consists of the following:

1. A new power steering pump belt to extend the belt's service life.
2. An improvement in the protection of the starter motor.
NOTE! For additional information, please see *Starter Motor* on page 3.

Upgrade No. 4 – Follow process steps outlined below

Model	Specification No.	Serial No.
BY (mechanical steering)	3868747	Lower than 4110164980
BY (power steering)	3868748	Lower than 4110164980

Upgrade No.4 consists of an improvement in the protection of the starter motor.
NOTE! For additional information, please see *Starter Motor* on page 3.

Starter Motor

Removal



DANGER! Do not substitute an automotive type starter. The Volvo Penta starter motor meets U.S. Coast Guard regulations for external ignition proof operation and marine use. The Volvo Penta starter is specially designed not to cause ignition of fuel vapors in the bilge or engine compartment. The use of automotive type starters can result in fire and explosion.

1. Disconnect the battery ground cable at battery and disconnect all wires at solenoid terminals to prevent sparks in engine compartment.
2. Remove the nut from the starter support bracket. Take out the starter mounting screws and remove the starter assembly.
3. Clean the surface of the starter with electrical contact cleaner or equivalent.
4. Using silicone or RTV sealer, apply a bead in the area indicated below **A**. Seal the gap all around the starter solenoid. Follow the sealant manufacturer's instructions and allow adequate drying time before reinstalling the starter.

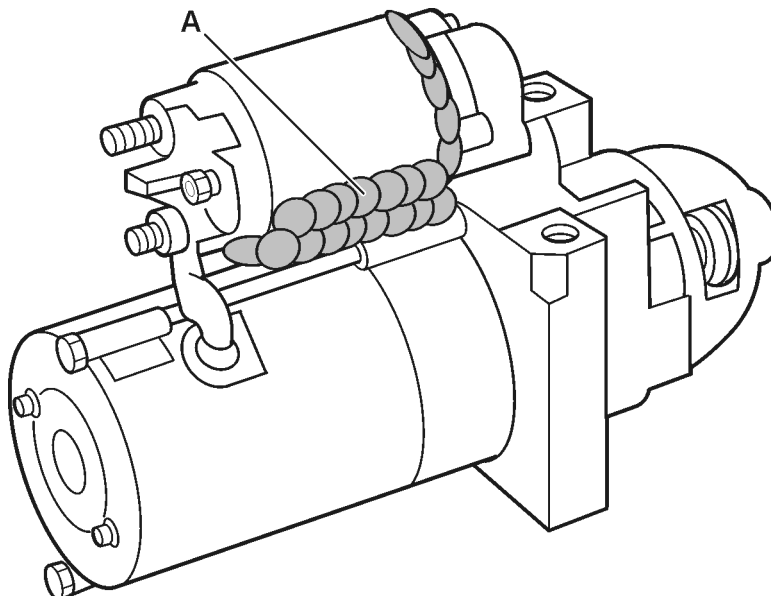

gr970440

Installation

1. To reinstall, position the starter assembly on the engine and start the mounting hardware.
2. Snug hardware while holding the starter squarely against its mounting surface. Tighten the screws to 30–36 ft. lb. (41–49 Nm).
3. Connect wires to solenoid and apply black Neoprene dip or equivalent to terminals to prevent corrosion.
4. Reconnect the battery ground cable at the battery. Attach the bell housing drain hose to the solenoid with a tie strap.

WT Model Upgrade

The modifications introduced with Kit PN 3861710 includes the following changes:

- Replace the raw water pump impeller cam.
- Replace the thermostat housing.
- Make changes to the routing of the water flow on the engine.

For specific information that is provided in the installation instructions included in kit PN 3861710, please refer to the document entitled *3.0GS "WT" Model Upgrade Kit* (PN 7741335).

EF Model Upgrade

In a continued effort to improve product reliability and performance, Volvo Penta of the Americas, Inc., has introduced two new 3.0 liter upgrade kits.

- Kits 3861709 and 3861708 are to be use on:
 - All "EF" models that have specification nos. 3869051 up to serial number 4012011158.
 - All "EF" models that have specification nos. 3869052 up to serial number 4012011347.**NOTE!** Please ensure that both kits are installed at this time.
- Kit 3861708 is to be used on:
 - All "EF" models that have specification nos. 3869051 from serial number 4012011159.
 - All "EF" models that have specification nos. 3869052 from serial number 4012011348.

Proper installation of these kits will unify the cooling systems and enhance performance on these models. Follow ALL installation instructions carefully using only original Volvo Penta parts and kits. These kits are ordered from Volvo Penta parts in the usual manner.

For specific information that is provided in the installation instructions included in kit PNs 3861709 and 3861708, please refer to the documents entitled *3.0GS Upgrade Kit* (PN 7741333) and *Carburetor Spacer Kit* (PN 7741334).