



Service Bulletin

Bulletin No. 2006-18

Jet Drive No. 2006-01

OEM No. 2006-05

Circulate to: Sales Manager Accounting Service Manager Technician Parts Manager

SportJet 200 HP OptiMax Fuel Lift Pump (Electric)

Models Affected

Models Covered	Serial Number Or Year
Mercury SportJet 200 HP OptiMax	S/N 0E432496 to 0E433492

Situation

The 2.5L 200 HP OptiMax SportJet may exhibit a no fuel condition resulting in: no start, hard to start, or the engine may stall.

Inspection

A simple fuel pump lift test, as described in the appropriate service manual section, can be used to determine if the pump is functioning to specification.

The fuel lift pump is designed to lift fuel vertically about 152.4 cm (60 in.), if there are no other restrictions in the system, using a fuel hose that is 7.9 mm (5/16 in.) minimum diameter.

As restrictions are added (such as filters, fittings, valves etc.) the amount of fuel pump lift decreases.

Fuel pump vacuum and air bubbles in the fuel supply can be checked with a vacuum gauge, a t-fitting, and a clear piece of fuel hose. Connect the clear hose between the inlet fitting on the fuel lift pump and the vacuum gauge t-fitting, keeping the t-fitting as close as possible to the pump. Connect the fuel line from the fuel tank to the remaining connection on the t-fitting.

THE INFORMATION IN THIS DOCUMENT IS CONFIDENTIAL AND PROTECTED BY COPYRIGHT AND IS THE PROPERTY OF MERCURY MARINE.

This document is provided for the sole and exclusive use of the original recipient as prescribed by Mercury Marine and may not be distributed or copied, digitally or otherwise, without the prior written consent of Mercury Marine.

Before proceeding with the system vacuum test, confirm that the fuel lift pump is capable of supplying the required vacuum. To do this, start the engine and pinch off/restrict the fuel supply hose between the vacuum gauge and fuel tank. The vacuum gauge should rise to or exceed the maximum normal reading of 2.5 inches vacuum (mercury). If it fails to reach this minimum number, the pump needs servicing.

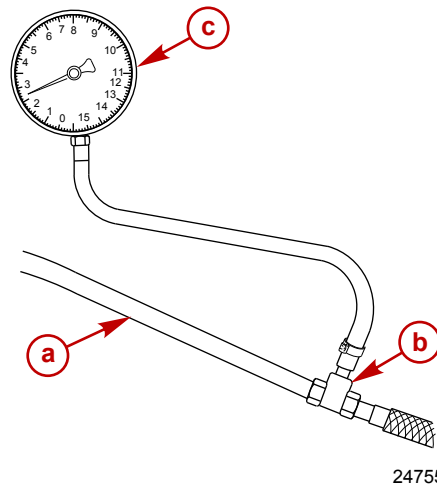

a - Clear hose
b - T-fitting

c - Vacuum gauge

Correction

If the lift pump fails the previous test, replace the 2.5L lift pump (P/N 880001A03) with the 3.0L lift pump (P/N 885555T03.)

Fuel Lift Pump Removal/Disassembly

1. Disconnect fuel pump harness connector.
2. Disconnect the fuel hose from the fuel filter.
3. Use a sharp side cutter or end cutter to peel back the end of the clamp securing the vapor separator hose. Remove hose from fuel pump.

THE INFORMATION IN THIS DOCUMENT IS CONFIDENTIAL AND PROTECTED BY COPYRIGHT AND IS THE PROPERTY OF MERCURY MARINE.

This document is provided for the sole and exclusive use of the original recipient as prescribed by Mercury Marine and may not be distributed or copied, digitally or otherwise, without the prior written consent of Mercury Marine.

- Loosen the bolt securing the pump retaining clamp and remove the pump.

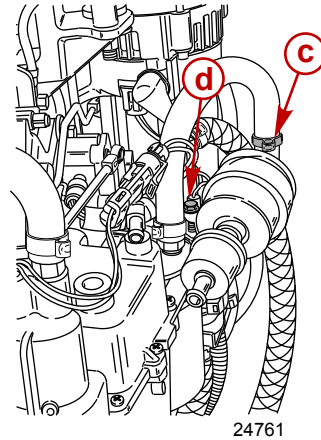
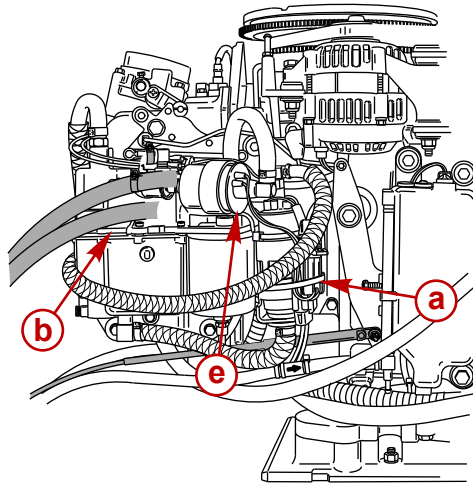

- a - Harness connector
- b - Fuel hose
- e - Fuel pump

- d - Bolt
- c - Clamp

Cleaning/Inspection

There are no serviceable parts within the electric fuel pump. However, there is a replaceable fuel filter on the pump which should be replaced every 100 hours or once a season. Use a strap wrench to remove filter.

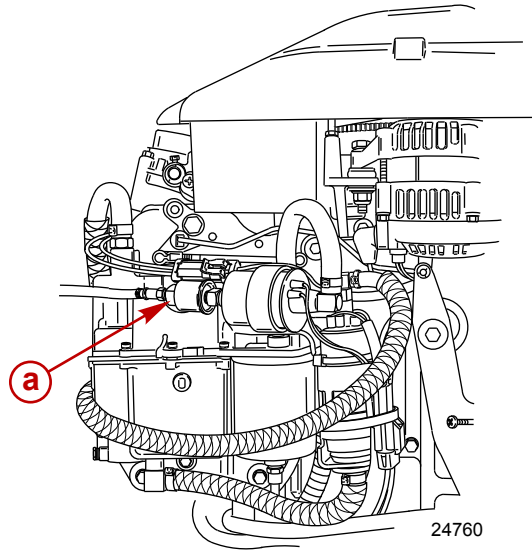

- a - Fuel filter

Reassembly/Installation

ASSEMBLY

- Install the fuel pump inside the retaining clamp. Secure the clamp with a screw.

Description	Nm	lb. in.	lb. ft.
Screw	16.0	145	

THE INFORMATION IN THIS DOCUMENT IS CONFIDENTIAL AND PROTECTED BY COPYRIGHT AND IS THE PROPERTY OF MERCURY MARINE.

This document is provided for the sole and exclusive use of the original recipient as prescribed by Mercury Marine and may not be distributed or copied, digitally or otherwise, without the prior written consent of Mercury Marine.

2. Reconnect the harness connector.
3. Reconnect the fuel tank hose to the filter. Use a stainless hose clamp to secure the fuel hose.
4. Reconnect the vapor separator fuel hose to the fuel pump. Secure the hose with clamp #183. Use the clamp tool (91-803146T) to secure clamp.
5. Run the engine and check for leaks.

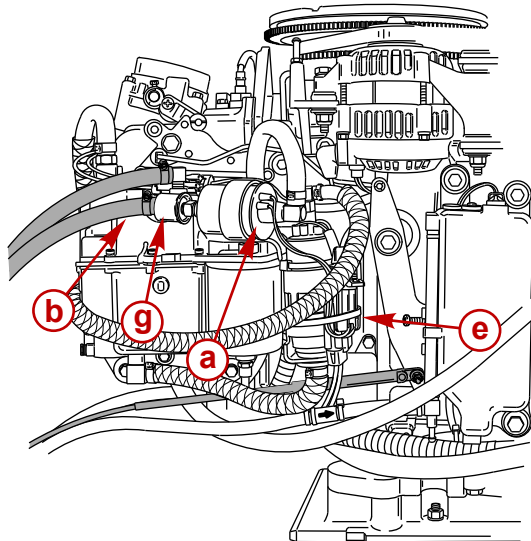

- a - Fuel pump
- b - Stainless hose clamp
- c - Hose clamp #183
- d - Screw

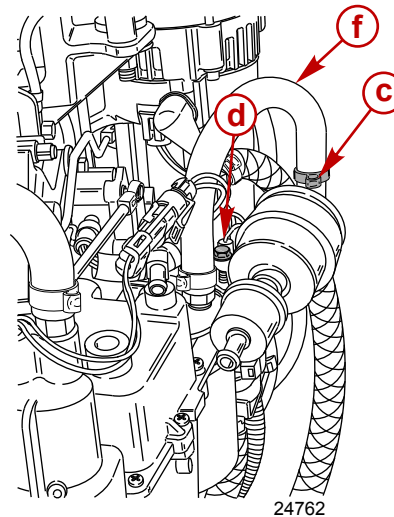

- e - Harness connector
- f - Fuel hose
- g - Filter

Description	Nm	lb. in.	lb. ft.
Screw	16.0	145	

Part Interchangeability

Mercury Marine Service Parts has superseded P/N 880001A03 to P/N 885555T03.

Parts Required

Qty.	Description	Part Number
1	Lift pump	885555T03

Warranty

Complete the warranty claim for the lift pump in MercNET identifying SportJet Service Bulletin 2006-01, and include a copy with your parts return for the complete kit listing:

- Lift Pump (P/N 880001A03)
- Quantity of Lift Pumps
- Labor time of 0.5 hours for diagnosis
- Labor time of 0.5 for pump replacement
- Part Code 732

THE INFORMATION IN THIS DOCUMENT IS CONFIDENTIAL AND PROTECTED BY COPYRIGHT AND IS THE PROPERTY OF MERCURY MARINE.

This document is provided for the sole and exclusive use of the original recipient as prescribed by Mercury Marine and may not be distributed or copied, digitally or otherwise, without the prior written consent of Mercury Marine.

- Failure Code 00
- Warranty Flat Rate Code: SB10

Dealer Parts Inventory

Complete the warranty claim for the lift pump in MercNET identifying SportJet Service Bulletin 2006-01, and include a copy with your parts return for the complete kit listing:

- Lift Pump (P/N 880001A03)
- Quantity of Lift Pumps
- Part Code 732
- Failure Code 00

Return Details

US AND CANADA:

Complete/process the claim via MercNET or return a warranty claim form.

INTERNATIONAL:

Follow instructions issued by Marine Power International office or by an authorized Marine Power Distributor.

THE INFORMATION IN THIS DOCUMENT IS CONFIDENTIAL AND PROTECTED BY COPYRIGHT AND IS THE PROPERTY OF MERCURY MARINE.

This document is provided for the sole and exclusive use of the original recipient as prescribed by Mercury Marine and may not be distributed or copied, digitally or otherwise, without the prior written consent of Mercury Marine.